

PANDUIT P/N	WEIGHT
P16B04M	2.0kg

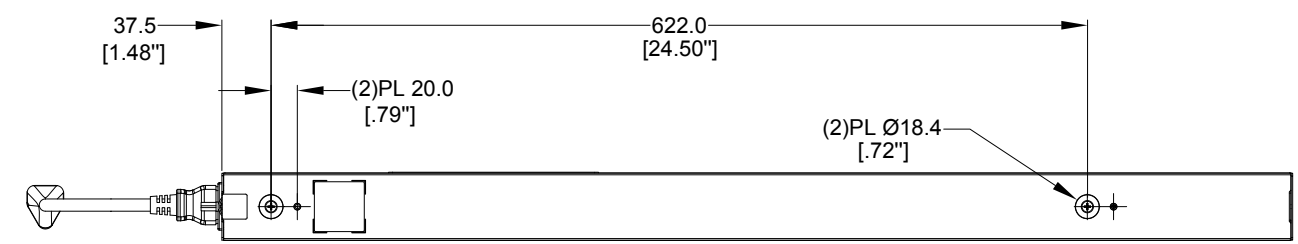

REAR VIEW

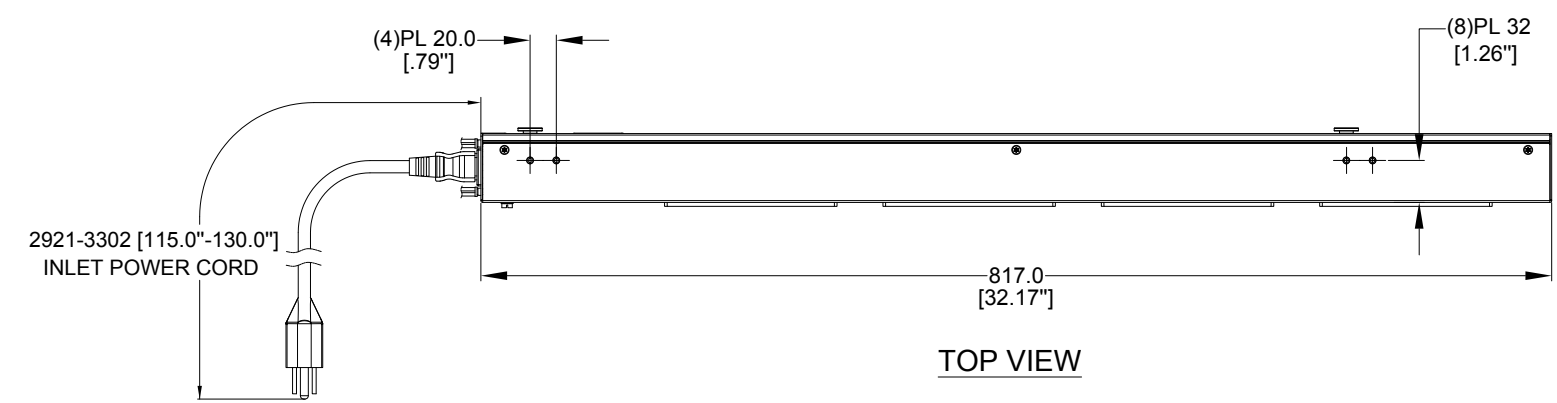

TOP VIEW

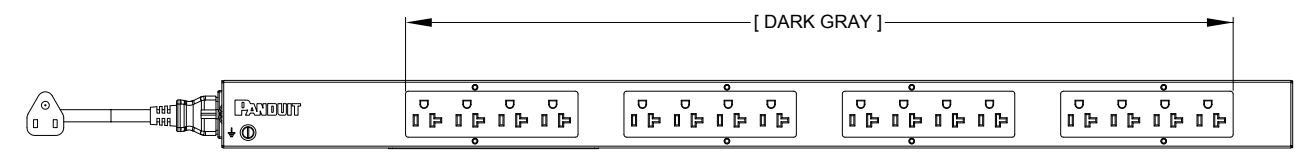

FRONT VIEW

NOTES:

- IDENTIFICATION:
 - UNIT TYPE: BASIC
 - ORIENTATION: VERTICAL, HALF
 - OUTLET QTY&TYPE: (16) 5-20R
 - BREAKER QTY&TYPE: N/A
 - INPUT VOLTAGE: 100-120VAC
 - INPUT CURRENT: 15A (12A DERATED)
 - INPUT PHASE: SINGLE-PHASE
 - RATED POWER: 1.9kVA
 - INPUT PLUG: NEMA 5-15P
 - INPUT CORD LENGTH: 3m [10']
- ACCESSORIES:
 - POCKET GUIDE
- RoHS COMPLIANT
- VISIT PANDUIT'S ON-LINE CATALOG AT WWW.PANDUIT.COM FOR ADDITIONAL PRODUCT INFORMATION CONTAINED IN THE SPECIFICATION SHEET AS WELL AS A CURRENT LIST OF PRODUCTS APPLICABLE FOR USE WITH THIS PART
- MAXIMUM ALLOWABLE INPUT POWER = 1.9kW
- INSTALLATION SHALL COMPLY WITH ALL APPLICABLE NATIONAL, STATE, AND LOCAL CODES

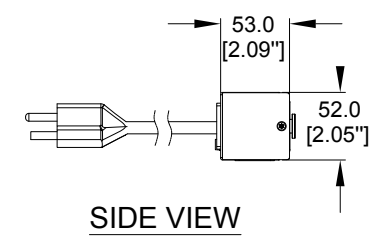

SIDE VIEW

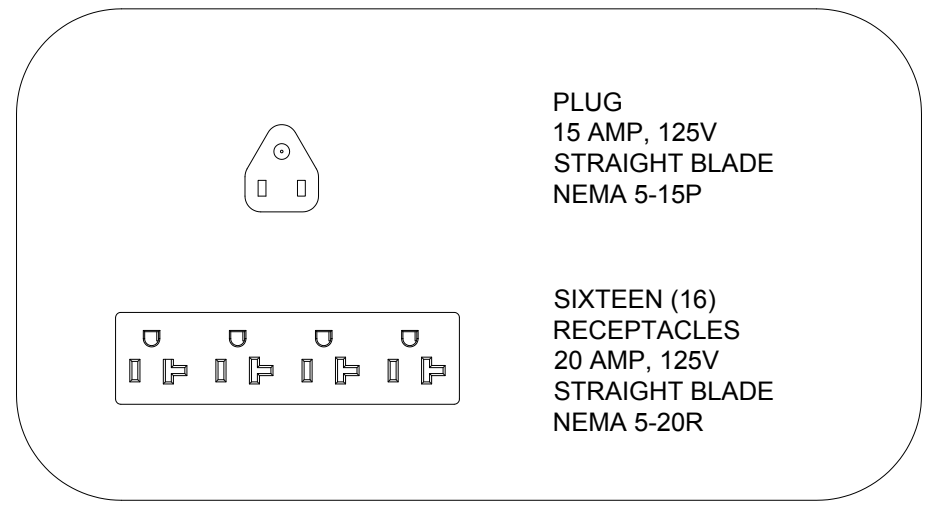

REV	DATE	BY	CHK	APR	DESCRIPTION	ECN
01B	08/21/2017	ZHAI	MIM	EDM	REVISED TOLERANCES AND INPUT CURRENT	P16B04M
01A	06/28/2017	ZHAI	MIM	EDM	INITIAL RELEASE	P16B04M

WE ASK THAT YOU CHECK FULLY THE DIMENSIONS, NOTES, AND SIGN THE CLIENT SIGNATURE BOX. THE JOB WILL NOT PROGRESS WITHOUT SIGNED APPROVAL. PLEASE DO NOT DELAY IN RETURNING PROOF AS IT WILL AFFECT DELIVERY		SIGN
		DATE
		PRINT
TITLE: BASIC SERIES PDU P16B04M CUSTOMER DRAWING		
ITEM REVISION NAME:		PANDUIT
DATASHEET FILE NAME:		
UNLESS OTHERWISE SPECIFIED DIMENSIONAL TOLERANCE ARE: mm [IN]		MATERIAL/COLOR: N/A
Tolerance(mm)		DRAWING NUMBER: P16B04M_DC
THIRD ANGLE PROJECTION		SCALE: SHT 1 OF 1
DRAWN BY: DI.ZHAI	DATE: 05/24/2017	SCALE: NONE
CHK: SEAN		SCALE: B